

SECTION 12 CONTAINERISED TRAFFIC

- 12.1 General Transportation
- 12.2 ISO Containers
- 12.3 Non- ISO Units
- 12.4 Route & Wagon Capabilities
- 12.5 Loading & Securing Containers on Rail
- 12.6 Multiple Stacked Containers
- 12.7 Containers in HSB Bins
- 12.8 Container Types
- 12.9 Twistlocks

This Section covers the use of all types of containers, including

- ➔ Dry Box Containers.
- ➔ Integral Boxes.
- ➔ Open Sided and Open Top Containers.
- ➔ Tank Containers and Pods.

See Diagram 12.24 for pictures of container types.

12.1 GENERAL TRANSPORTATION

Four factors are most significant:

- ➔ Condition
- ➔ Weight
- ➔ Height
- ➔ Nature of the Load

CONDITION

KiwiRail will not accept any container or unit for rail transport with cracking around the corner castings, in welds or in any other structurally important area. This is to protect KiwiRail's staff and infrastructure, as well as the general public and their property.

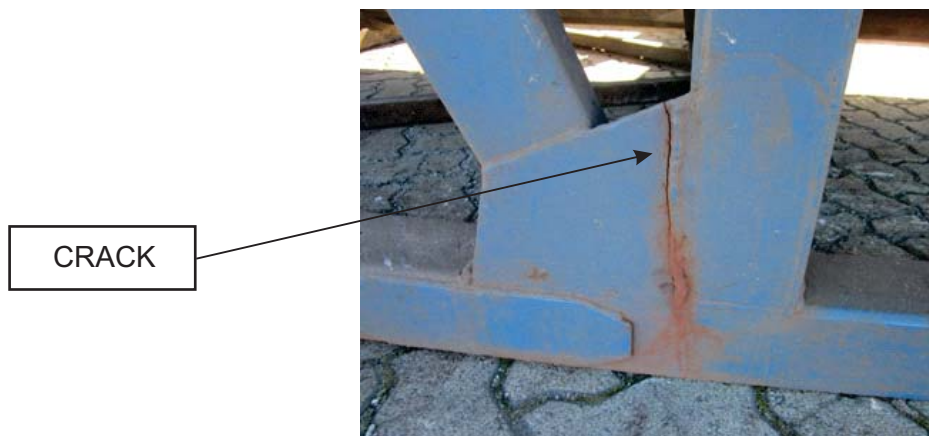

WEIGHT

BEFORE LOADING, DO...

- ➔ Check the **gross weight** on the documentation and ensure...
 - ➔ The container is not overloaded.
 - ➔ The wagon is not loaded beyond its design limits (see Section 12.2).
 - ➔ The wagon will be loaded within its limits for the route (see Section 12.2).
- Note: Overloads are not allowed without specific permission from the Manager Wagons. Such permission will only be granted in special cases and will be authorised by Bulletin. Permission will not be granted for overloading UK wagons.

HEIGHT

BEFORE LOADING, DO...

- ➔ **Check the height and type** of wagon it is loaded on against the route restrictions. See Diagrams 12.2 and 12.3.

NATURE OF THE LOAD

DANGEROUS GOODS

For **dangerous goods** refer to other Sections of this Manual as follows:

- ➔ Section 6 for Compliance Requirements.
- ➔ Section 7 for Sender's Responsibilities.

CHILLED & FROZEN FREIGHT

Chilled and frozen freight may have generator attachments to provide temperature control similar to integral boxes. When using Clip-on Refrigeration Units it is important that these units are correctly secured to the wagon,

DO...

- ✓ Check that the generator weight has been included in the total load.
- ✓ Check that the generator is working correctly.
- ✓ Check that the generator is properly secured, and that any power cables to other wagons are cabled tied and wagons kidney linked.

CUSTOMS & BOND FREIGHT

Customs and bond freight (freight awaiting duty payment before release) must be handled in accordance with Customs Regulations. Bonded freight can be sent only to locations with recognised bond storage facilities. Section 8 of this Manual indicates the bond stores operated by KiwiRail.

ONION CONTAINERS

Fan ventilated containers loaded with onions travel between MetroPort Auckland and Port of Tauranga. These containers may travel with one end door, in the direction of travel, held open about 100mm by a wooden block. On road the door is held against the block using 6 mm polyrope. On rail the door must be secured against the blocking using two special 25 mm webbing belts secured as shown below. These belts are manufactured for KiwiRail by Ancra NZ (Ancra part no. Tranz-009). The belts are to be removed at Tauranga and returned to MetroPort Auckland for re-use. If the special belts are not available, two standard 50mm webbing straps may be used, either secured right across the end of the container, or between the door locking bars.

DO NOT...

- ✗ Secure doors against blocking with polyrope for rail movement.

DO...

- ✓ Secure doors against the blocking with the correct straps threaded through the buckle

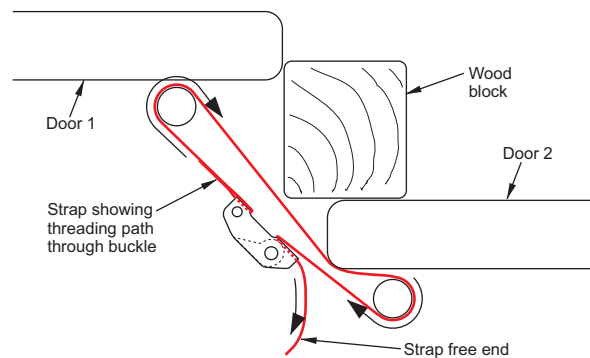

Correct threading of strap through buckle.



Doors secured using correct strap and buckle.

STOWAGE

Freight shall be loaded into containers in accordance with all the principles of good stowage, load stability and so on as described in Sections 5 and 6 of this Manual. Refer also to Sections 20 and 21 for palletised and loose general freight.

12.2 ISO CONTAINERS

Typical Container Life-Cycle																
Yr 1	Yr 2	Yr 3	Yr 4	Yr 5	Yr 6	Yr 7	Yr 8	Yr 9	Yr 10	Yr 11	Yr 12	Yr 13	Yr 14	Yr 15	...	Yr 20
International Shipping Service										2nd Hand - Domestic Service				Retire Yr 15-20		
ISO Design Life																
Initial CSC Certification					1st Inspection			2nd Inspection			Annual Inspections					

Standard ISO containers can be recognised by their current CSC SAFETY APPROVAL plate or Inspection Certificate. Most have a BIC code that is unique to the original owner e.g. KiwiRail's BIC code prefix is "KRCU".

CSC SAFETY APPROVAL plates can be recognized as current if the inspection date has not expired or if it has a valid ACEP ID on the plate. Think of the CSC plate as the containers WoF, it's a good indication that the container is being maintained to an acceptable standard.

Details for companies who have certified container inspectors in centres around NZ are available on http://www.iicl.org/directory/companies_container.cfm#NewZealand. The duration of CSC inspection after the initial certification provided by the container factory is at the discretion of the inspector and may be anywhere between 3 and 36 months.

Figure 1 above illustrates a typical container life cycle in relation to its likely inspection regime.

Strictly the CSC approval system applies to internationally shipped containers. However second-hand containers used in NZ domestic traffics are a big potential risk group to KiwiRail if they are not maintained to a structurally sound standard. Therefore customers who operate such containers must make a safety declaration to their KiwiRail Account Manager. The safety declaration must identify which recognised container maintenance and inspection regime they will apply to their equipment. The regime may be to continue with CSC maintenance and inspection or it may be an alternative recognised standard.

12.3 NON-ISO UNITS

Non-ISO units (eg curtain-side containers, accommodation units, oil & gas exploration equipment) are sometimes presented for movement by rail as containers, meaning that four twistlocks alone would secure the container to the wagon. To be accepted, these units must meet the conditions below.

A **loaded** non-ISO unit can be accepted for rail transport as a container **only if** it meets all four of the following conditions:

- ➔ It is a single unit with twistlock connections in the ISO positions, which will ensure it physically fits on the wagon and
- ➔ It has a current CSC Plate or Inspection Certificate, or it has an alternative design / manufacturing / maintenance certificate. ➔

It is not structurally cracked or corroded, and ➔ It's size and weight are within the allowable limit.

An **empty** non-ISO unit can be accepted for rail transport as a container if:

- ➔ It meets the criteria for a loaded non-ISO unit above, OR
- ➔ It meets all of the following conditions:
 - ➔ It has twistlock connections in the ISO positions, which will ensure it physically fits on the wagon, and
 - ➔ It is not structurally cracked or corroded, and
 - ➔ It is within the allowable limits for size and weight, and
- ➔ It passes a KiwiRail visual inspection by a competent person.

DO...

- ✓ Ensure that the unit is entirely within a standard or hi-cube (route dependant) container profile
- ✓ Secure or remove accessories or potentially loose items, including doors, windows and vents.
- ✓ Check that any load securing curtains and all supporting items such as curtain end poles, buckles, roof support poles and strops, are in good working condition, correctly fitted in place and fully secured as the design or certificate intended.

If you think the documentation is inadequate or you are uncertain about a non-ISO unit, particularly if a unit is in poor condition, contact contact KiwiRail's Container Asset Manager or Fleet Engineering. IF IN DOUBT - ASK

In any case, loaded or empty, a container or unit with any cracking visible to the naked eye is not to be accepted for rail transportation.

NON-ISO UNITS continued

The flowchart guides you in making a decision about whether any container, or container-like unit can be carried by rail as a container:

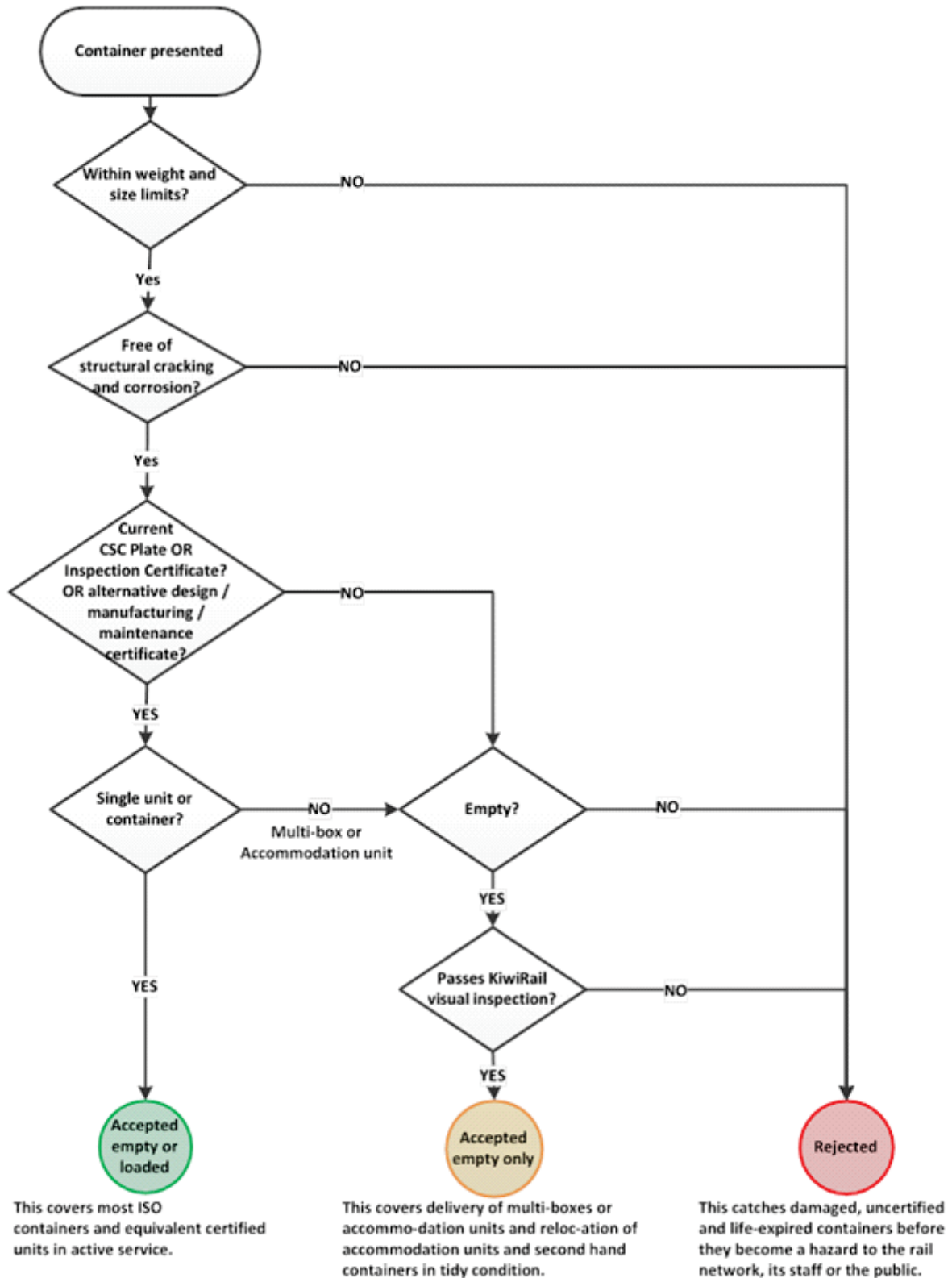

12.4 ROUTE & WAGON CAPABILITIES

The movement of containers by rail is limited by:

- Wagon load capability.
- Container movement (height) restrictions over certain routes.
- Axle load limitations on certain routes.

KiwiRail has defined running rights for wagons and wagon-container combinations, for more information contact our Customer Service Centre on 0800 351-351

WAGON CAPABILITIES

Diagram 12.1 describes wagon load capabilities.

CONTAINER MOVEMENT RESTRICTIONS

All containers are nominally outside the Standard Loading Gauge (SLG). However, containers with a height at the corners of 2.6 m (8 feet 6 inches) or less can be carried nationally.

High Cube containers with a height at the corners of 2.9m (9 feet, 6 inches) can be carried on many routes.

High Cube containers with a height at the corners of 3.05m (10 feet) can be carried on specific routes only.

For more information contact our Customer Service Centre on 0800 351-351

AXLE LOAD LIMITATIONS

Axle loads of up to 18 tonne are permitted on many routes, but some routes are limited to 16.3 tonne per axle or 14.3 tonne per axle.

For more information contact our Customer Services Centre on 0800 351-351

DIAGRAM 12.1 WAGON CAPABILITIES

WAGON CLASS	MAXIMUM AXLE LOAD	MAXIMUM CAPACITY (TEU's)	MAXIMUM 3M BOX <i>If singly loaded on outer slot, weight in brackets must apply</i>	MAXIMUM 6M BOX <i>If dually loaded on outer slots</i>	MAXIMUM 6M BOX <i>If singly loaded on outer slot</i>	MAXIMUM 6M BOX <i>If loaded on inner slot or centre slot for wagons marked with (*)</i>	MAXIMUM 6M BOX <i>If loaded in 'Very Heavy' position</i>	MAXIMUM 7.5M BOX <i>If singly loaded on outer slot</i>	MAXIMUM 12M BOX <i>If weight in brackets reached, no other box permitted</i>
PK	14.3	2	14 (10.5)	25.5	25.5	-	-	-	30.5
PKD (LCS)	15.25	2	14 (10.5)	25.5	25.5	-	-	-	34
USQ, USR	14.3	2	-	25.5	25.5	-	-	-	30
USK	14.3	2	14 (14)	25.5	25.5	-	30.5	-	30.5
UK	14.3	2.5	14 (11)	23.5	19	25	-	25	34 (30.5)
UKD (LCS)	15.6	2.5	14 (11)	24	19	25	-	25	34 (30.5)
HK	16.3	2.5	14 (12)	27	21.5	29	-	30	34
IAB, IH	18	2.5	15.5 (12)	31	23	31.5	43	30.5	46.5
IA	18	2.5	15.5 (12)	31	23	31.5	-	31.5	35
IAC	18	2.5	15.5 (12)	31	21.5	31.5	43	30	47.5
IB	18	3	-	28	20	24*	-	-	30.5
IC	18	3	-	30	19	30*	-	-	35 (30.5)
IM	18	3	-	29	22	32*	-	-	35
IBB	18	3	-	28.5	21.5	35*	-	-	38
UDA	14.3	1	-	-	-	-	35	-	-
UDK	14.3	2	14 (12.5)	-	-	-	35	-	-

DIAGRAM 12.2 STANDARD SIZED CONTAINER MOVEMENT RESTRICTIONS: NORTH ISLAND
Sheet 1 of 2

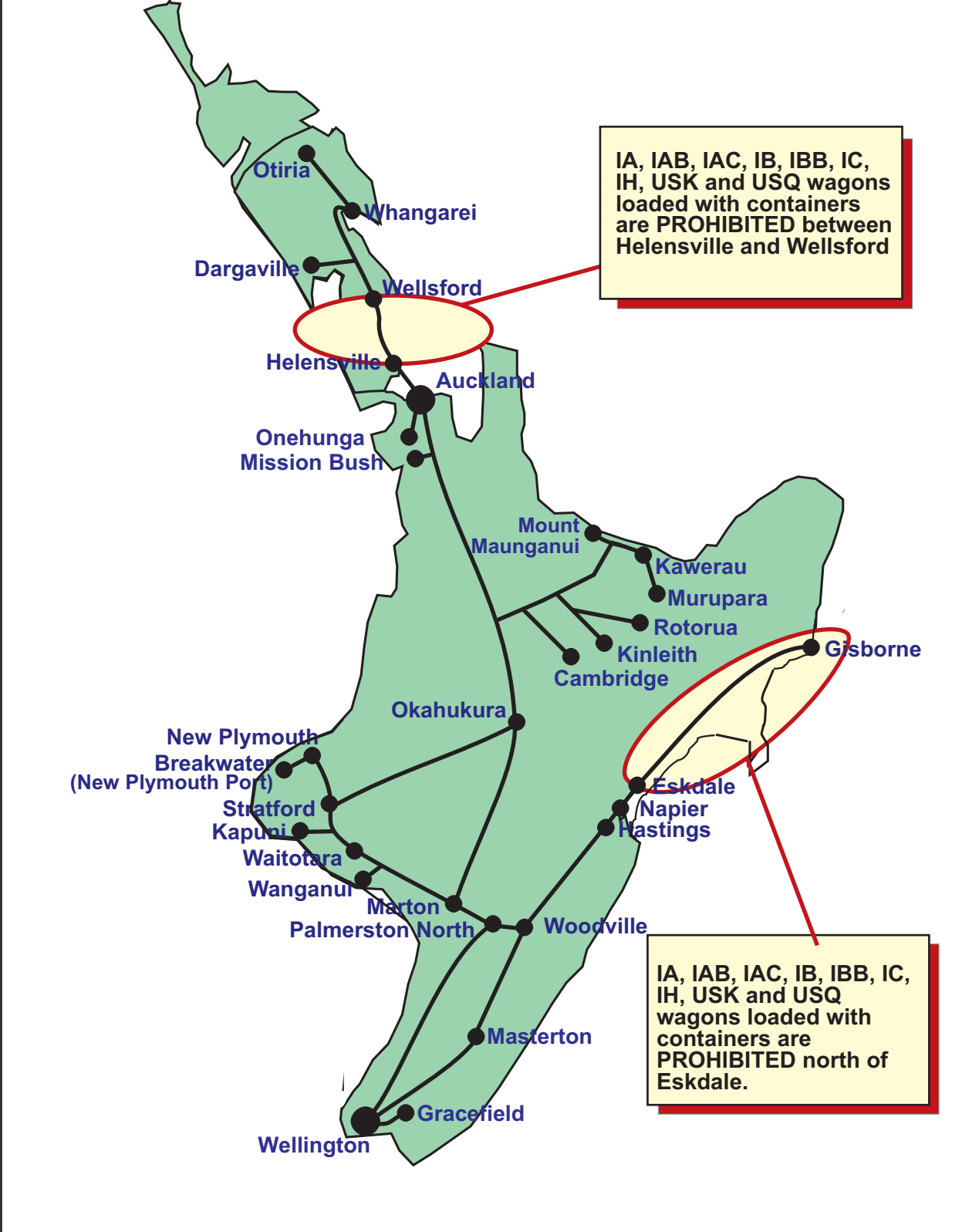

**DIAGRAM 12.2 STANDARD SIZED CONTAINER MOVEMENT
RESTRICTIONS: SOUTH ISLAND**
Sheet 2 of 2

**IB, IBB, and IC
wagons PROHIBITED
west of Springfield**

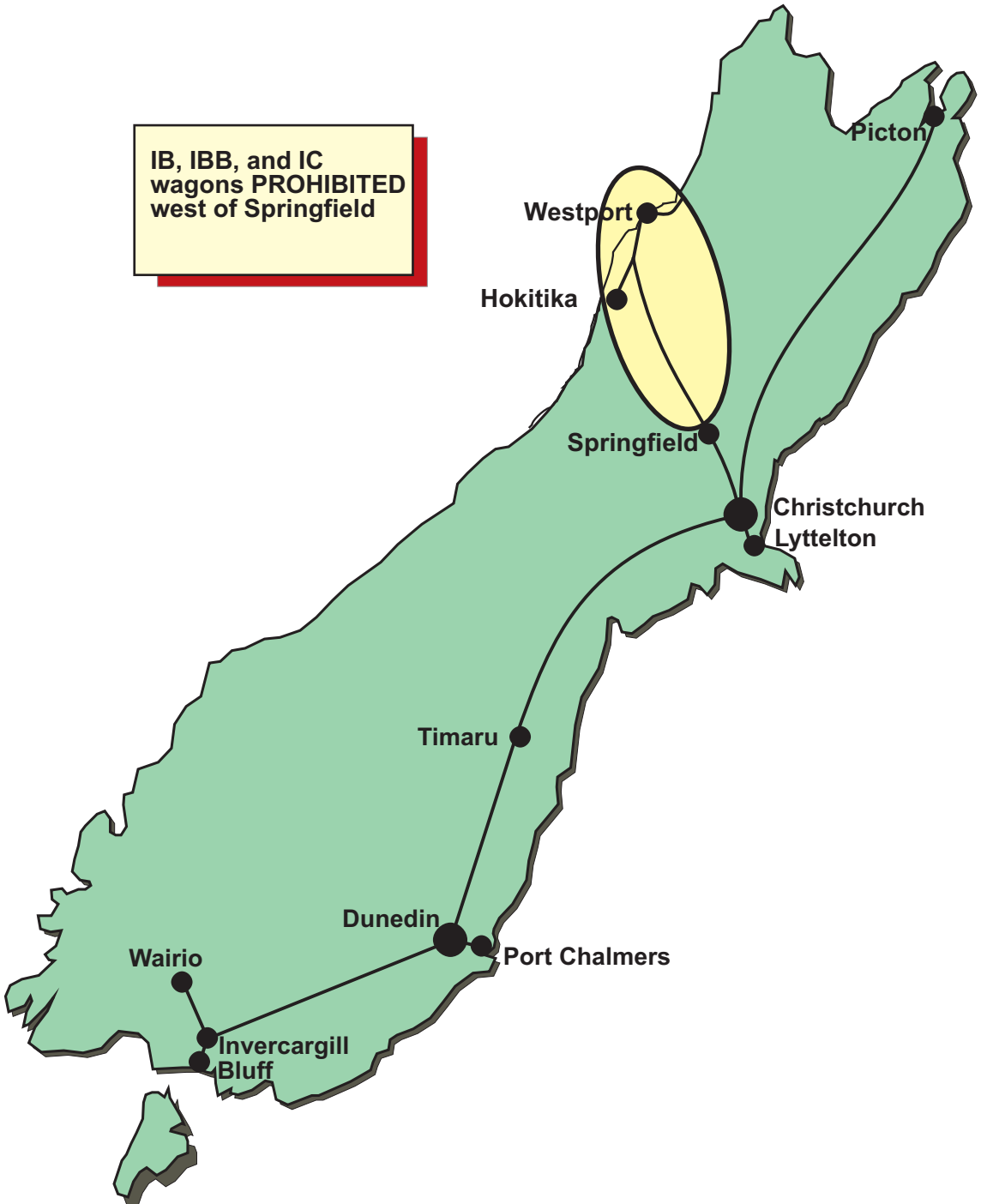

DIAGRAM 12.3 2.9m HIGH CUBE CONTAINER MOVEMENT RESTRICTIONS

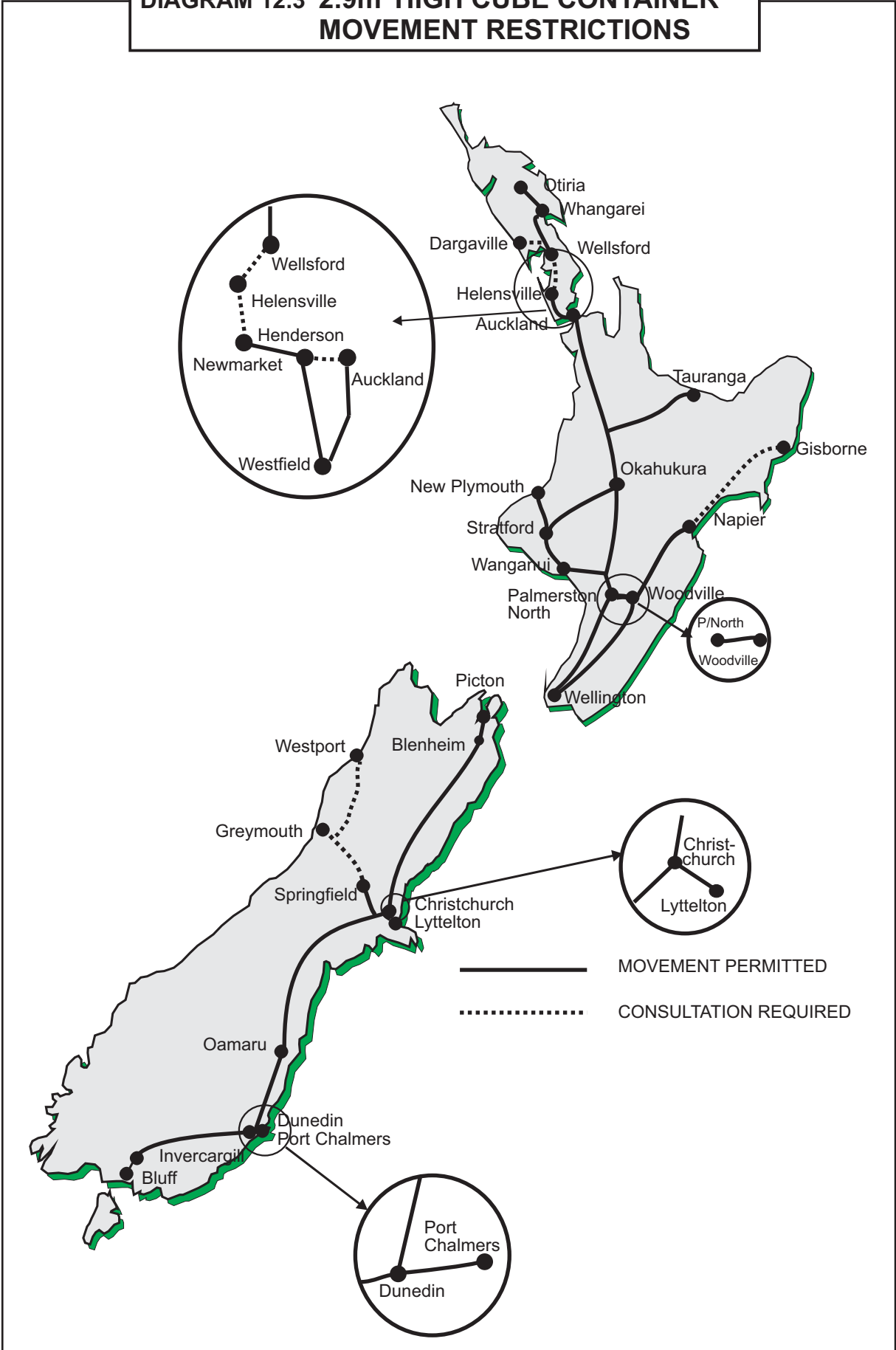

DIAGRAM 12.4 AXLE LOAD LIMITATIONS

Refer Section 22
Oversize & Overweight Loads

Page 22.11 and 22.12 for Axle Load Limitations
North & South Island

**DIAGRAM 12.5 CONTAINER-WAGON LOAD COMBINATIONS:
Heavy 6 m CONTAINERS or EQUIVALENTS
Sheet 1 of 2**

Heavy Loaded Gross Weight (tonnes)	Light Container Maximum Allowable Gross Weight (Tonne)					
	IA		IAB / IH		IAC	
	18T/axle	16.3T/axle	18T/axle	16.3T/axle	18T/axle	16.3T/axle
21.5	-	-	-	-	-	-
22.0	-	-	-	-	-	-
22.5	-	-	-	-	-	-
23.0	-	-	-	-	-	-
23.5	-	-	-	-	-	-
24.0	-	-	-	-	-	-
24.5	-	24.5	-	24.5	-	-
25.0	-	23.0	-	23.5	-	25.0
25.5	-	23.0	-	23.0	-	23.5
26.0	-	23.0	-	23.0	-	23.5
26.5	-	20.5	-	22.0	-	23.5
27.0	-	16.0	-	17.0	-	21.0
27.5	-	12.5	-	13.5	-	17.0
28.0	28.0	8.5	28.0	9.5	-	13.0
28.5	26.5	4.5	26.5	5.5	28.5	9.0
29.0	26.5		26.5		27.0	5.0
29.5	26.0		26.5		26.5	
30.0	24.5		26.0		26.5	
30.5	20.5		22.0		25.0	
31.0	16.5		17.5		21.0	
31.5	12.5		13.5		17.0	

DO...

- ✓ On IA, IAB, IAC and IH wagons load containers of the same weight symmetrically on either the inner or outer twistlocks. Symmetrically loaded containers can be each up to half of the maximum payload of the wagon. The maximum container weight for symmetrically loaded wagons is the top figure in each column in the table above. Note that for IA wagons on 16 tonne routes, all container combination weights (including symmetrical loads) are reduced.

- ✓ On IA, IAB, IAC and IH wagons, load the **heavier** of two containers on the **inner** twistlocks and the lighter of the two on the outer twistlocks.

- ✓ For IAB, IAC and IH single container loads in excess of these tabled above are allowable up to Diagram 12.1 maximum. Single heavy containers (i.e. those exceeding the weights tabled above) must be carried in the new “very heavy” container position.

**DIAGRAM 12.5 CONTAINER-WAGON LOAD COMBINATIONS:
Heavy 6 m CONTAINERS or EQUIVALENTS
Sheet 2 of 2**

Heavy Loaded Gross Weight (tonnes)	Light Container Maximum Allowable Gross Weight (tonne)				
	HK	PK	UK	USQ / USR	USK
21.5	-	-	21.5	20.0	19.5
22.0	-	22.0	20.0	18.0	17.5
22.5	-	19.0	20.0	15.5	15.5
23.0	-	16.0	18.0	13.5	13.5
23.5	-	13.0	13.5	11.0	11.5
24.0	-	10.5	9.5	9.0	9.5
24.5	-	7.5	5.0	6.5	7.5
25.0	25.0	4.5		4.0	5.5
25.5	23.5				3.5
26.0	23.5				
26.5	23.0				
27.0	19.5				
27.5	15.5				
28.0	11.5				
28.5	7.5				
29.0	3.5				
29.5					
30.0					
30.5					

DO NOT LOAD 2ND CONTAINER, AS EXCEEDS WAGON RATING

One 6m container up to 30.5t can be loaded centrally on USK

DO...

- ✓ On HK and UK load containers of the same weight symmetrically on either the inner or outer twistlocks. Symmetrically loaded containers can be each up to half of the maximum payload of the wagon. The maximum container weight for symmetrically loaded wagons is the top figure in each column in the table above. Note that for IA wagons on 16 tonne routes, all container combination weights (including symmetrical loads) are reduced.
- ✓ On HK and UK load the **heavier** of two containers on the **inner** twistlocks and the lighter of the two on the outer twistlocks.
Note: UK and PK wagons loaded with heavy containers at one end can become unstable and derail under some conditions.
Load combinations in the grey shaded areas above should be avoided where possible.
- ✓ Where only one container is allowed, load as centrally as possible. If not possible, see Diagram 12.1 for maximum weights.

**DIAGRAM 12.5A
CONTAINER-WAGON LOAD COMBINATIONS:
ONE HEAVY X 12M & ONE X 3M
CONTAINERS**

12M Box Gross Weight (tonnes)	Maximum 3M Box Gross Weight (tonne)				
	UK	HK	IA	IAB / IH	IAC
47.5	12m box exceeds wagon limit				9.0
47.0					9.5
46.5				9.0	9.5
46.0				9.5	10.0
45.0				9.5	10.0
44.0				10.0	10.5
43.0				10.5	11.0
42.0				11.0	11.5
41.0				11.5	11.5
40.0				11.5	12.0
39.0				12.0	12.5
38.0				12.5	13.0
37.0				13.0	13.5
36.0				13.0	13.5
35.0		13.5	13.5	14.0	
34.0	No other box allowed	11.0	14.0	14.0	14.5
33.0		11.5	14.5	14.5	15.0
32.0		12.0	15.0	15.0	15.5
31.0		12.5	15.0	15.0	15.5
30.5	9.0 9.0 9.5 10.0 10.5 10.5 11.0 11.5 12.0 12.0 12.5 13.0 13.5 14.0 14.0 14.5 15.0 15.5	12.5	15.5	15.5	15.5
30.0		12.5	Maximum allowable weight for 3M boxes		
29.0		13.0			
28.0		13.5			
27.0		14.0			
26.0		14.0			
25.0		14.5			
24.0		15.0			
23.0		15.5			
22.0					
21.0					
20.0					
19.0					
18.0					

DIAGRAM 12.5B CONTAINER-WAGON LOAD COMBINATIONS: APPROVED LOCAL CIRCUIT SHUNTS OPERATING AT 55km/h MAX					
Heavy Loaded 6m Gross Weight (tonnes)	Light 6m Container Maximum Allowable Gross Weight (tonne)				
	PKD	UKD / UKF	USR	USK	
21.5	-	-	21.5	21.5	
22.0	-	-	21.0	21.0	
22.5	-	-	15.5	15.5	
23.0	-	-	13.5	13.5	
23.5	-	-	11.0	11.5	
24.0	24.0	24.0	9.0	9.5	
24.5	7.5	5.0	6.5	7.5	
25.0	4.5		4.0	5.5	
25.5				3.5	
DO NOT LOAD 2ND CONTAINER, AS EXCEEDS WAGON RATING					

PKD wagons are selected PK wagons subject to more frequent inspections. They are authorised to operate **on specific Local Circuit Shunts** overloaded up to the limits in the table, **at no more than 55km/h**. See the latest issue of the Rail Operating Code for approved routes. 12m containers up to 34t are permitted on PKD wagons (no change to standard PK).

UKD wagons are selected UK wagons subject to more frequent inspections. They are authorised to operate **on specific Local Circuit Shunts** overloaded up to the limits in the table, **at no more than 55km/h**. See the latest issue of the Rail Operating Code for approved routes. 12m containers up to 34t are permitted on UKD wagons (no change from standard UK).

USR wagons are authorised to operate **on specific Local Circuit Shunts** overloaded up to the limits in the table, **at no more than 55km/h**. See the latest issue of the Rail Operating Code for approved routes. 12m containers up to 30t are permitted on USR wagons (no change from standard USR).

USK wagons are authorised to operate **on specific Local Circuit Shunts** overloaded up to the limits in the table, **at no more than 55km/h**. See the latest issue of the Rail Operating Code for approved routes. Note that USK wagons are able to carry one central 6m container up to 30.5t gross weight at line speed. 12m containers up to 30.5t are permitted on USK wagons (no change from standard USK).

IAD wagons have the same limits as standard IA wagons. The unique classification is for pool allocation only.

**DIAGRAM 12.6 MAXIMUM LOADING:
1 X 12M AND 1 X 6M CONTAINER**
Sheet 1 of 2

12M Container Maximum Gross Weight	6M Container Maximum Gross Weight			
	IB	IC	IM	IBB
38.0	DO NOT LOAD 12M BOX, AS EXCEEDS WAGON RATING	DO NOT LOAD 12M BOX, AS EXCEEDS WAGON RATING		1.5
37.5				5.9
37.0				10.3
36.5				14.8
36.0				18.1
35.5		18.2		
35.0		DO NOT LOAD 6M BOX, AS EXCEEDS WAGON RATING	18.3	18.4
34.5			18.4	18.5
34.0			18.6	18.7
33.5			18.7	18.8
33.0			18.9	19.0
32.5			19.1	19.2
32.0			19.2	19.3
31.5			19.4	19.5
31.0			19.5	19.6
30.5			19.7	19.8
30.0		21.2	20.8	19.7
29.5	21.3	21.0	19.8	
29.0	21.5	21.2	20.0	
28.5	21.6	21.3	20.2	
28.0	21.8	21.5	20.3	
27.5	22.0	21.6	20.5	
27.0	22.1	21.8	20.6	
26.5	22.3	22.0	20.8	
26.0	22.4	22.1	20.9	
25.5	22.6	22.3	21.1	
25.0	22.8	22.4	21.3	
24.5	22.9	22.6	21.4	
24.0	23.1	22.7	21.6	
23.5	23.2	22.9	21.7	
23.0	23.4	23.1	21.9	
22.5	23.6	23.2	22.0	
22.0	23.7	23.4	22.2	
21.5	23.9	23.5	22.4	
21.0	24.1	23.7	22.5	
20.5	24.2	23.9	22.7	
20.0	24.4	24.0	22.8	
19.5	24.5	24.2	23.0	
19.0	24.7	24.3	23.1	
18.5	24.9	24.5	23.3	
18.0	25.0	24.7	23.5	
17.5	25.2	24.8	23.6	
17.0	25.3	25.0	23.8	
16.5	25.5	25.1	23.9	
16.0	25.7	25.3	24.1	
15.5	25.8	25.4	24.3	
15.0	26.0	25.6	24.4	
	26.1	25.8	24.6	

**DIAGRAM 12.6 MAXIMUM LOADING:
1 X 12M AND 1 X 6M CONTAINER**
Sheet 2 of 2

12M Container Maximum Gross Weight	6M Container Maximum Gross Weight			
	IB	IC	IM	IBB
14.5	26.3	25.9	24.7	24.8
14.0	26.5	26.1	24.9	25.0
13.5	26.6	26.2	25.0	25.1
13.0	26.8	26.4	25.2	25.3
12.5	27.0	26.6	25.4	25.5
12.0	27.1	26.7	25.5	25.6
11.5	27.3	26.9	25.7	25.8
11.0	27.4	27.0	25.8	25.9
10.5	27.6	27.2	26.0	26.1
10.0	27.8	27.3	26.1	26.3
9.5	27.9	27.5	26.3	26.4
9.0	28.0	27.7	26.5	26.6
8.5	28.0	27.8	26.6	26.7
8.0	28.0	28.0	26.8	26.9
7.5	28.0	28.1	26.9	27.0
7.0	28.0	28.3	27.1	27.2
6.5	28.0	28.5	27.2	27.4
6.0	28.0	28.6	27.4	27.5
5.5	28.0	28.8	27.6	27.7
5.0	28.0	28.9	27.7	27.8
4.5	28.0	29.1	27.9	28.0
4.0	28.0	29.3	28.0	28.1

**DIAGRAM 12.7 IB WAGON LOAD COMBINATIONS:
16.3 tonne AXLE LOAD**

16.3 TONNE AXLE LOAD: THREE × 6 m CONTAINERS

First End Container: Maximum Gross Weight (tonnes)	Middle Container: Maximum Gross Weight (tonnes)	Second End Container: Maximum Gross Weight (tonnes)
12.5	24.0	12.5
13.0	23.0	13.0
13.5	21.0	13.5
14.5	19.0	14.5
15.5	17.0	15.5
16.5	15.0	16.5
17.5	13.0	17.5
18.5	11.0	18.5
19.5	9.0	19.5
20.5	7.0	20.5
21.5	5.0	21.5
22.5	3.0	22.5
23.0	No middle container	23.0
24.0	No middle container	24.0

**16.3 TONNE AXLE LOAD:
ONE × 12 m & ONE × 6 m CONTAINER**

12 m Container: Maximum Gross Weight (tonnes)	6 m Container: Maximum Gross Weight (tonnes)
30.5	16.5
30.0	16.5
29.0	17.0
28.0	17.5
27.0	17.5
26.0	18.0
25.0	18.5
24.0	18.5
23.0	19.0
22.0	19.0
21.0	19.5
20.0	20.0
19.0	20.0
18.0	20.5
17.0	21.0
16.0	21.0
15.0	21.5
14.0	22.0
13.0	22.0
12.0	22.5
11.0	23.0
10.0	23.0
9.0	23.5
8.0	23.5

**DIAGRAM 12.8 IB WAGON LOAD COMBINATIONS:
18 tonne AXLE LOAD**

18 TONNE AXLE LOAD: THREE × 6 m CONTAINERS

First End Container: Maximum Gross Weight (tonnes)	Middle Container: Maximum Gross Weight (tonnes)	Second End Container: Maximum Gross Weight (tonnes)
16.0	24.0	16.0
17.0	22.0	17.0
18.0	20.0	18.0
19.0	18.0	19.0
20.0	16.0	20.0
21.0	14.0	21.0
22.0	12.0	22.0
23.0	10.0	23.0
24.0	8.0	24.0
25.0	6.0	25.0
26.0	4.0	26.0
27.0	2.0	27.0
28.0	No Middle Container	28.0

Note: If the first end container weighs between 19 and 28 tonnes, there **must** be a container loaded on the second end to prevent an End to End loading imbalance

**DIAGRAM 12.9 IBB WAGON LOAD COMBINATIONS:
16.3 tonne AXLE LOAD**

16.3 TONNE AXLE LOAD: THREE × 6 m CONTAINERS

First End Container: Maximum Gross Weight (tonnes)	Middle Container: Maximum Gross Weight (tonnes)	Second End Container: Maximum Gross Weight (tonnes)
5.5	35.0	5.5
6.0	34.0	6.0
7.0	32.0	7.0
8.0	30.0	8.0
9.0	28.0	9.0
10.0	26.0	10.0
11.0	24.0	11.0
12.0	22.0	12.0
13.0	20.0	13.0
14.0	18.0	14.0
15.0	16.0	15.0
16.0	14.0	16.0
17.0	12.0	17.0
18.0	10.0	18.0
19.0	8.0	19.0
20.0	6.0	20.0
21.0	4.0	21.0
22.0	2.0	22.0
23.0	No Middle Container	23.0

**16.3 TONNE AXLE LOAD:
ONE × 12 m & ONE × 6 m CONTAINER**

12 m Container: Maximum Gross Weight (tonnes)	6 m Container: Maximum Gross Weight (tonnes)
32.5	-
32.0	4.5
31.5	9.0
31.0	13.5
30.5	15.0
30.0	15.5
28.5	16.0
25.5	17.0
22.5	18.0
19.0	19.0
16.0	20.0
13.0	21.0
9.5	22.0
6.5	23.0
3.5	24.0
-	25.0

**DIAGRAM 12.10 IBB WAGON LOAD COMBINATIONS:
18 tonne AXLE LOAD**

18 TONNE AXLE LOAD: THREE × 6 m CONTAINERS

First End Container: Maximum Gross Weight (tonnes)	Middle Container: Maximum Gross Weight (tonnes)	Second End Container: Maximum Gross Weight (tonnes)
9.5	35.0	9.5
10.0	34.0	10.0
11.0	32.0	11.0
12.0	30.0	12.0
13.0	28.0	13.0
14.0	26.0	14.0
15.0	24.0	15.0
16.0	22.0	16.0
17.0	20.0	17.0
18.0	18.0	18.0
19.0	16.0	19.0
20.0	14.0	20.0
21.0	12.0	21.0
22.0	10.0	22.0
23.0	8.0	23.0
24.0	6.0	24.0
25.0	4.0	25.0
26.0	2.0	26.0
27.0	No Middle Container	27.0

Note: If the first end container weighs between 21.5 and 28.5 tonnes, there **must** be a container loaded on the second end to prevent an End to End loading imbalance

**DIAGRAM 12.11 IBB WAGON LOAD COMBINATIONS:
20 tonne AXLE LOAD**

20 TONNE AXLE LOAD: THREE × 6 m CONTAINERS

First End Container: Maximum Gross Weight (tonnes)	Middle Container: Maximum Gross Weight (tonnes)	Second End Container: Maximum Gross Weight (tonnes)
13.5	35.0	13.5
14.0	34.0	14.0
15.0	32.0	15.0
16.0	30.0	16.0
17.0	28.0	17.0
18.0	26.0	18.0
19.0	24.0	19.0
20.0	22.0	20.0
21.0	20.0	21.0
22.0	18.0	22.0
23.0	16.0	23.0
24.0	14.0	24.0
25.0	12.0	25.0
26.0	10.0	26.0
27.0	8.0	27.0
28.0	6.0	28.0
29.0	4.0	29.0
30.0	2.0	30.0
31.0	No Middle Container	31.0

**20 TONNE AXLE LOAD:
ONE × 12 m & ONE × 6 m CONTAINER**

12 m Container: Maximum Gross Weight (tonnes)	6 m Container: Maximum Gross Weight (tonnes)
38.0	21.5
37.0	22.5
34.0	23.0
31.0	24.0
27.0	25.0
24.0	26.0
21.5	27.0
18.0	28.0
15.0	29.0
12.0	30.0
8.0	31.0
5.5	32.0
-	33.0

20t AXLE LOAD IS NOT CURRENTLY PERMITTED

USE 18t AXLE LOAD CHART (DIAGRAM 12.1)

**DIAGRAM 12.12 IC WAGON LOAD COMBINATIONS:
16.3 tonne AXLE LOAD**

16.3 TONNE AXLE LOAD: THREE × 6 m CONTAINERS

First End Container: Maximum Gross Weight (tonnes)	Middle Container: Maximum Gross Weight (tonnes)	Second End Container: Maximum Gross Weight (tonnes)
8.5	30.5	8.5
11.5	25.0	11.5
12.5	23.0	12.5
13.5	21.0	13.5
14.5	19.0	14.5
15.5	17.0	15.5
16.5	15.0	16.5
17.5	13.0	17.5
18.5	11.0	18.5
19.5	9.0	19.5
20.5	7.0	20.5
21.5	5.0	21.5
22.5	3.0	22.5
23.0	No middle container	23.0
24.0	No middle container	24.0

**16.3 TONNE AXLE LOAD:
ONE × 12 m & ONE × 6 m CONTAINER**

12 m Container: Maximum Gross Weight (tonnes)	6 m Container: Maximum Gross Weight (tonnes)
30.5	16.0
30.0	16.0
29.0	16.5
28.0	17.0
27.0	17.0
26.0	17.5
25.0	17.5
24.0	18.0
23.0	18.5
22.0	18.5
21.0	19.0
20.0	19.5
19.0	19.5
18.0	20.0
17.0	20.0
16.0	20.5
15.0	21.0
14.0	21.0
13.0	21.5
12.0	22.0
11.0	22.0
10.0	22.5
9.0	23.0
8.0	23.0

**DIAGRAM 12.13 IC WAGON LOAD COMBINATIONS:
18 tonne AXLE LOAD**

18 TONNE AXLE LOAD: THREE × 6 m CONTAINERS

First End Container: Maximum Gross Weight (tonnes)	Middle Container: Maximum Gross Weight (tonnes)	Second End Container: Maximum Gross Weight (tonnes)
13.0	30.5	13.0
14.0	28.5	14.0
15.0	26.5	15.0
16.0	24.5	16.0
17.0	22.5	17.0
18.0	20.5	18.0
19.0	18.5	19.0
20.0	16.5	20.0
21.0	14.5	21.0
22.0	12.5	22.0
23.0	10.5	23.0
24.0	8.5	24.0
25.0	6.6	25.0
26.0	4.5	26.0
27.0	2.5	27.0
28.0	No Middle Container	28.0
28.5	No Middle Container	22.0
29.0	No Middle Container	15.0
29.5	No Middle Container	10.0
30.0	No Middle Container	3.5

Note: If the first end container weighs between 19 and 30 tonnes, there **must** be a container loaded on the second end to prevent an End to End loading imbalance

**DIAGRAM 12.14 IM WAGON LOAD COMBINATIONS:
18 tonne AXLE LOAD**

18 TONNE AXLE LOAD: THREE × 6 m CONTAINERS		
First End Container: Maximum Gross Weight (tonnes)	Middle Container: Maximum Gross Weight (tonnes)	Second End Container: Maximum Gross Weight (tonnes)
10.6	32.5	10.6
10.9	32.0	10.9
11.9	30.0	11.9
12.9	28.0	12.9
13.9	26.0	13.9
14.9	24.0	14.9
15.9	22.0	15.9
16.9	20.0	16.9
17.9	18.0	17.9
18.9	16.0	18.9
19.9	14.0	19.9
20.9	12.0	20.9
21.9	10.0	21.9
22.9	8.0	22.9
23.9	6.0	23.9
24.9	4.0	24.9
25.9	2.0	25.9
26.9	No Middle Container	26.9

Note: If the first end container weighs between 22 and 29 tonnes, there **must** be a container loaded on the second end to prevent an End to End loading imbalance

**DIAGRAM 12.15 IM WAGON LOAD COMBINATIONS:
20 tonne AXLE LOAD**

20 TONNE AXLE LOAD: THREE × 6 m CONTAINERS

First End Container: Maximum Gross Weight (tonnes)	Middle Container: Maximum Gross Weight (tonnes)	Second End Container: Maximum Gross Weight (tonnes)
14.6	32.5	14.6
14.9	32.0	14.9
15.9	30.0	15.9
16.9	28.0	16.9
17.9	26.0	17.9
18.9	24.0	18.9
19.9	22.0	19.9
20.9	20.0	20.9
21.9	18.0	21.9
22.9	16.0	22.9
23.9	14.0	23.9
24.9	12.0	24.9
25.9	10.0	25.9
26.9	8.0	26.9
27.9	6.0	27.9
28.9	4.0	28.9
29.9	2.0	29.9
30.9	No Middle Container	30.9

**20 TONNE AXLE LOAD:
ONE × 12 m & ONE × 6 m CONTAINER**

12 m Container: Maximum Gross Weight (tonnes)	6 m Container: Maximum Gross Weight (tonnes)
No 12 m Container	32.5
5.0	32.0
6.1	31.0
11.3	30.0
14.5	29.0
17.7	28.0
20.8	27.0
24.0	26.0
27.2	25.0
30.4	24.0
33.5	23.0
36.0	22.5

20t AXLE LOAD IS NOT CURRENTLY PERMITTED

USE 18t AXLE LOAD CHART (DIAGRAM 12.10)

**DIAGRAM 12.16 CONTAINER-WAGON LOAD LIMITATIONS:
WITH CENTRAL 3.05 m CONTAINERS**

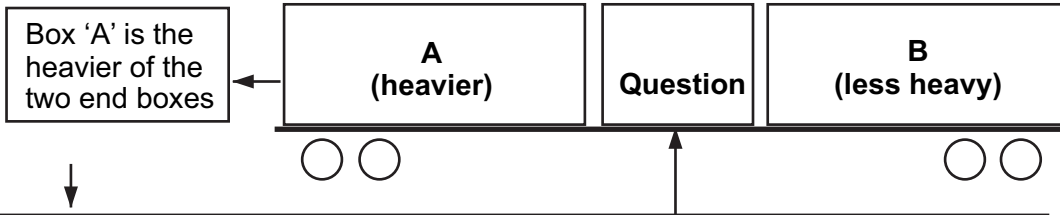

Box 'A' Maximum Gross Weight	Central Container Maximum Allowable Gross Weight (tonnes)					
	IA		IAB / IH		IAC	
	18T/axle	16.3T/axle	18T/axle	16.3T/axle	18T/axle	16.3T/axle
13.0	15.5	15.5	15.5	15.5	15.5	15.5
14.0	15.5	15.5	15.5	15.5	15.5	15.5
15.0	15.5	15.5	15.5	15.5	15.5	15.5
16.0	15.5	15.5	15.5	15.5	15.5	15.5
17.0	15.5	15.0	15.5	15.5	15.5	15.5
18.0	15.5	13.0	15.5	13.0	15.5	14.0
19.0	15.5	11.0	15.5	11.0	15.5	12.0
20.0	15.5	9.0	15.5	9.0	15.5	10.0
21.0	14.0	7.0	14.0	7.0	15.0	8.0
22.0	12.0	5.0	12.0	5.0	13.0	6.0
23.0	10.0	3.0	10.0	3.0	11.0	4.0
24.0	8.0		8.0	1.0	9.0	2.0
25.0	6.0		6.0		7.0	
26.0	4.0		4.0		5.0	
27.0	2.0		2.0		3.0	

	HK	UK	PK
13.0	15.5	14.0	
14.0	15.5	14.0	
15.0	15.5	13.0	
16.0	15.5	11.0	
17.0	15.5	9.0	
18.0	14.0	7.0	
19.0	12.0	5.0	
20.0	10.0	3.0	
21.0	8.0		
22.0	6.0		
23.0	4.0		
24.0		Central Box Not Allowed	
25.0			
26.0			
27.0			

**DIAGRAM 12.17 CONTAINER-WAGON LOAD LIMITATIONS:
WITH CENTRAL 3.05 m CONTAINERS**

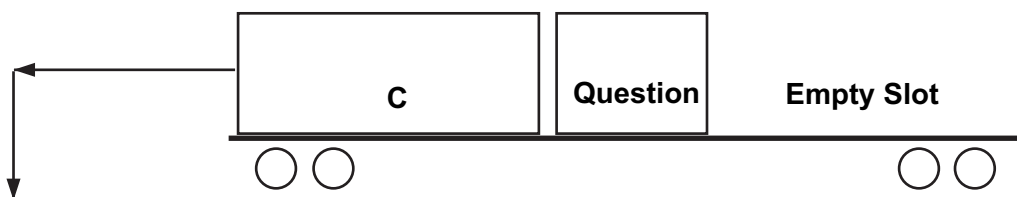

Box 'C' Maximum Gross Weight	Central Container Maximum Allowable Gross Weight (tonnes)					
	IA		IAB / IH		IAC	
	18T/axle	16.3T/axle	18T/axle	16.3T/axle	18T/axle	16.3T/axle
13	15.5	15.5	15.5	15.5	15.5	15.5
14	15.5	15.5	15.5	15.5	15.5	15.5
15	15.5	15.5	15.5	15.5	15.5	15.5
16	15.5	15.5	15.5	15.5	15.5	15.5
17	15.5	15.5	15.5	15.5	15.5	15.5
18	15.5	15.5	15.5	15.5	15.5	15.5
19	15.5	15.0	15.5	15.0	15.5	15.5
20	15.5	13.5	15.5	13.0	15.5 (2.0)	14.5 (2.0)
21	15.5	11.5	15.5	11.5	15.5 (2.5)	12.5 (2.5)
22	15.5	10.0	15.5	9.5	15.5 (3.0)	10.5 (3.0)
23	15.0	8.0	14.5	8.0	15.5 (3.5)	9.0 (3.5)
24	13.0 (1.5)	6.0 (1.5)	13.0 (1.5)	6.0 (1.5)	14.0 (4.0)	7.0 (4.0)
25	11.0 (2.0)	4.5 (2.0)	11.0 (2.0)	4.5 (2.0)	12.0 (5.0)	5.5 (5.0)
26	9.5 (2.5)		9.0 (2.5)		10.5	
27	7.5 (3.0)		7.5 (3.0)		8.5	
28	6.0 (4.0)		5.5 (3.5)		7.0	
29	4.0 (4.5)		4.0 (4.0)		5.0	

	HK	UK	PK	
13	15.5	14.0		
14	15.5	14.0		
15	15.5	14.0		
16	15.5	14.0		
17	15.5	12.0		
18	15.5	10.5		
19	15.5	8.5		
20	14.5	7.0 (1.0)		
21	12.5			
22	11.0 (1.0)	Central Box Not Allowed		
23	9.0 (1.5)			
24	7.0 (2.0)			
25	5.5 (2.5)			

Numbers in brackets is the minimum weight for the centre 3m container to prevent End to End loading imbalances

**DIAGRAM 12.18 CONTAINER-WAGON LOAD LIMITATIONS:
3.05 m CONTAINERS
Sheet 1 of 2**

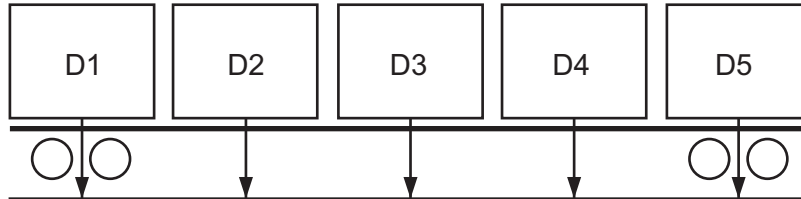

FOR IA 18T / axle	MAXIMUM GROSS WEIGHT COMBINATIONS (tonnes)				
	15.5	15.5	-	-	15.5
	15.0	7.0	15.0	-	15.5
	14.0	14.0	-	14.0	14.0
	13.0	13.0	4.0	13.0	13.0
	11.0	11.0	12.0	11.0	11.0
	15.0	13.0	-	13.0	15.0

FOR IA 16.3T / axle	MAXIMUM GROSS WEIGHT COMBINATIONS (tonnes)				
	15.0	12.5	-	-	15.0
	15.5	2.0 (MT)	15.0	-	15.5
	12.0	11.5	2.0 (MT)	11.5	12.0
	12.5	12.0	-	12.0	12.5
	10.0	10.0	9.0	10.0	10.0
	15.0	9.5	-	9.5	15.0

FOR IAB / IH 18T / axle	MAXIMUM GROSS WEIGHT COMBINATIONS (tonnes)				
	15.5	15.5	-	-	15.5
	15.0	7.0	15.0	-	15.5
	14.0	14.0	-	14.0	14.0
	13.0	13.0	4.0	13.0	13.0
	11.0	11.0	12.0	11.0	11.0
	15.0	13.0	-	13.0	15.0

FOR IAB / IH 16.3T / axle	MAXIMUM GROSS WEIGHT COMBINATIONS (tonnes)				
	15.0	12.5	-	-	15.0
	15.5	2.0 (MT)	15.0	-	15.5
	12.0	11.5	2.0 (MT)	11.5	12.0
	12.5	12.0	-	12.0	12.5
	10.0	10.0	9.0	10.0	10.0
	15.0	9.5	-	9.5	15.0

**DIAGRAM 12.18 CONTAINER-WAGON LOAD LIMITATIONS:
3.05 m CONTAINERS
Sheet 2 of 2**

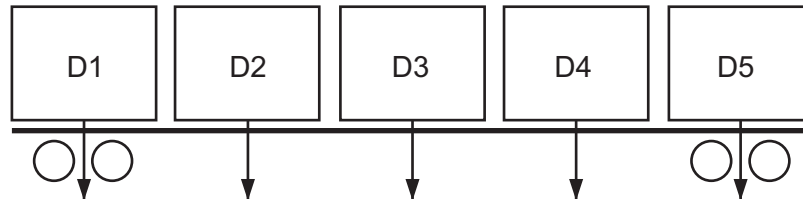

FOR IAC 18T / axle	MAXIMUM GROSS WEIGHT COMBINATIONS (tonnes)				
	15.5	15.5	-	-	15.5
	15.0	7.5	15.0	-	15.5
	14.0	14.5	-	14.5	14.0
	13.0	13.5	4.0	13.5	13.0
	11.0	11.0	12.0	11.0	11.0
	15.0	13.5	-	13.5	15.0

FOR IAC 16.3t / axle	MAXIMUM GROSS WEIGHT COMBINATIONS (tonnes)				
	15.0	13.0	-	-	15.0
	15.5	2.0 (MT)	15.5	-	15.5
	12.0	12.0	2.0 (MT)	12.0	12.0
	12.5	12.5	-	12.5	12.5
	10.0	10.0	10.0	10.0	10.0
	15.0	10.0	-	10.0	15.0

FOR UK	MAXIMUM GROSS WEIGHT COMBINATIONS (tonnes)				
	14.0	7.5	-	7.5	14.0
	14.0	-	14.0	-	14.0
	12.0	8.0	2.0 (MT)	8.0	12.0
	11.0	10.0	-	10.0	11.0
	9.0	8.0	8.0	8.0	9.0

FOR HK	MAXIMUM GROSS WEIGHT COMBINATIONS (tonnes)				
	14.0	14.0	-	-	14.0
	14.0	2.0 (MT)	14.0	2.0 (MT)	14.0
	12.0	13.0	-	13.0	12.0
	13.0	12.0	-	12.0	13.0
	10.0	10.0	10.0	10.0	10.0

**DIAGRAM 12.19 CONTAINER-WAGON LOAD LIMITATIONS:
1x 6m CONTAINER and 2x 3.05m CONTAINERS
Sheet 1 of 1**

6m container on outer twistlocks

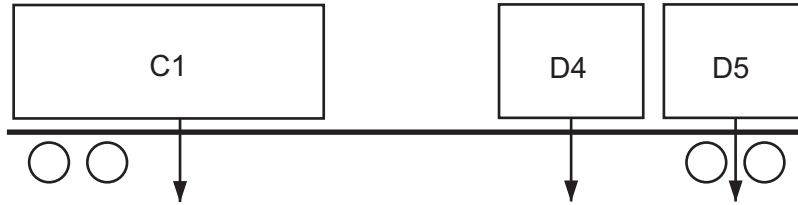

**FOR
IAB / IH
18T / axle**

MAXIMUM GROSS WEIGHT COMBINATIONS (tonnes)			
30.5	-	3.1	With no 3m container in D5 Slot
29.0	-	9.1	
28.0	-	13.0	
27.3	-	15.5	
27.6	-	15.5	13.0 (9.0)
27.8	-	15.0	13.3 (4.0)
28.0	-	14.0	14 (10.0)
28.3	-	13.0	14.8 (11.5)
28.6	-	12.0	15.5 (13.5)
29.0	-	10.6	15.5 (15.5)
30.5	-	4.7	15.5 (15.5)
31.5	-	-	15.5

6m container on inner twistlocks

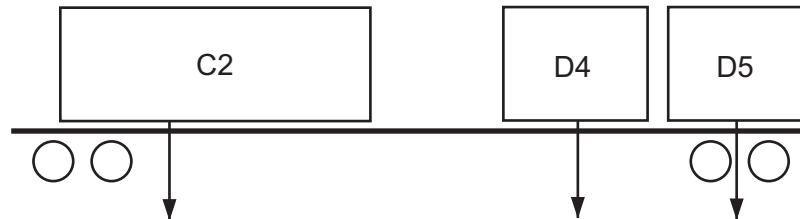

**FOR
IAB / IH
18T / axle**

MAXIMUM GROSS WEIGHT COMBINATIONS (tonnes)			
31.5	-	5.5	With no 3m container in D5 Slot
30.5	-	9.2	
29.0	-	14.9	
28.8	-	15.5	
28.0	-	15.5	11.7
28.0	-	15.0	12.0
29.0	-	14.0	12.7
29.5	-	13.0	13.3
30.0	-	12.0	14.0 (8.5)
30.5	-	10.0	15.5 (7.5)
31.5	-	-	15.5

Numbers in brackets is the minimum weight for the 3m container in the D5 slot to prevent End to End loading imbalances

12.5 LOADING & SECURING CONTAINERS ON RAIL

DO...

- ✓ Load containers onto the wagon directly **without** dunnage.
- ✓ Ensure that **all** containers have **all twistlocks up, locked and pinned/tied**.
Diagram 12.20 shows how rail twistlocks are secured and pinned/tied.
- ✓ Always load LGD and LTD tank containers with the **outlet pipe** to the **centre** of the wagon.

AUTOMATIC TWISTLOCKS

Several types of automatic twistlocks are fitted to wagons (such as the OM and USQ). Specific instructions on the operation of automatic twistlocks are shown in Diagram 12.21.

GENERAL RESTRICTION

DO NOT...

- ✗ **DO NOT** load GST and TST KiwiRail containers on PK wagons.
- ✗ **DO NOT** load GST, GSY, GTX, and TST KiwiRail containers on the ends of HK, IA, IB and UK wagons; load only in the centre position.

HCC, HEC and HLC CONTAINERS

HCC, HEC, and HLC containers may be placed on HK, IA, IB and UK wagons as follows :-

- ➔ Loaded on the outer twistlocks: The doors must face inboard, i.e., toward the centre of the wagon.
- ➔ Loaded on the inner twistlocks: No restriction on the way the doors face.

In all cases the door lever locking pins must be in place at all times.

TSM and GSM CONTAINERS

- TSM and GSM containers are 7.6m long and fitted with three sets of bottom ISO securing fittings.
- They are specifically designed to overhang into the central space on UK, IA and IB wagons when fitted to the outer 6m container slots.
- These containers are 2.9m high so are subject to route restrictions.
- Due to the large internal volume of these containers, they can be very heavy.
- Load ratings for these wagons must not be exceeded when carrying these containers

TSD CONTAINERS

- TSD containers are 7.6m long and fitted with three sets of bottom ISO securing fittings.
- They are specifically designed to overhang into the central space on UK, IA and IB wagons when fitted to the outer 6m container slots.
- These containers are 3.05m high so are permitted on specifically authorised routes only.
- Due to the large internal volume of these containers, they can be very heavy.
- Load ratings for these wagons must not be exceeded when carrying these containers

45 FOOT CONTAINERS

- Most 45 foot containers are fitted with extra bottom castings at 12m container centre distance away from each end.
- These containers can be carried on any 12m container capable wagon using the 12m container twistlocks with the extra length accommodated on the wagon deck
- Do not exceed the wagon load rating for 12m containers

UES 45 FOOT CONTAINERS

- UES 45 foot containers have extra bottom castings at 12m container spacing with an overhang at each end.
- On most KiwiRail wagons this results in the container overhanging the headstock, which is not acceptable.
- They may be carried on specially modified UKV wagons.
- These wagons have extra twistlocks fitted to engage with the bottom castings on the containers.

12.6 MULTIPLE STACKED CONTAINERS

This section applies to all multiple stacked containers, including halfheights, collapsible flatracks and platform containers.

MULTIPLE STACKING RULES

- ➔ The gross weight of multiple stacked containers **shall not exceed** the weight limits defined for standard height containers (see Section 12.4).
- ➔ The combined height of multiple stacked containers must not exceed the maximum container height for the route.

DO...

- ✓ Secure the bottom container to the wagon with all four twistlocks up, locked and pinned or tied.
- ✓ Lock the containers to each other at each corner using built-in connectors or double-ended shipping twistlocks.
- ✓ Secure the collapsed end walls (bulkheads) of the top collapsed flatrack to its platform, and ensure the lock down mechanisms are engaged

ADDITIONALLY ...

- ✓ **For spring loaded bulkheads**, the bulkheads must be secured with a minimum of two strops **or chains** tensioned over each bulkhead.
- ✓ **For non spring loaded bulkheads**, the bulkheads must be secured with a minimum of one strop **or chain** tensioned over each bulkhead.
- ✓ **Strops** must be at least 38mm wide, and compliant with AS/NZS4380

DO NOT...

- ✗ **DO NOT** stack **loaded** containers on top of **empty** containers.

12.7 CONTAINERS IN HSB BINS

HSB scrap bins may carry loaded or empty containers (6 m × 2.5 m × 2.6 m) when not loaded with anything else. Maximum weight depends on wagon and route restrictions.

12.8 CONTAINER TYPES

Diagram 12.24 illustrates the container types most frequently found in the KiwiRail system.

12.9 TWISTLOCKS

Twistlocks with worn side pins

- ➔ Twistlocks have been found with worn side pins, which may permit the twistlock to rotate when loaded
- ➔ Twistlocks with worn side pins are being modified with the addition of a security pin.

Twistlocks with security pins

- ➔ Security pins will prevent the twistlock from rotating when the security pin is engaged.
- ➔ Security pins **MUST** be placed in the locked position when the twistlock is in use.

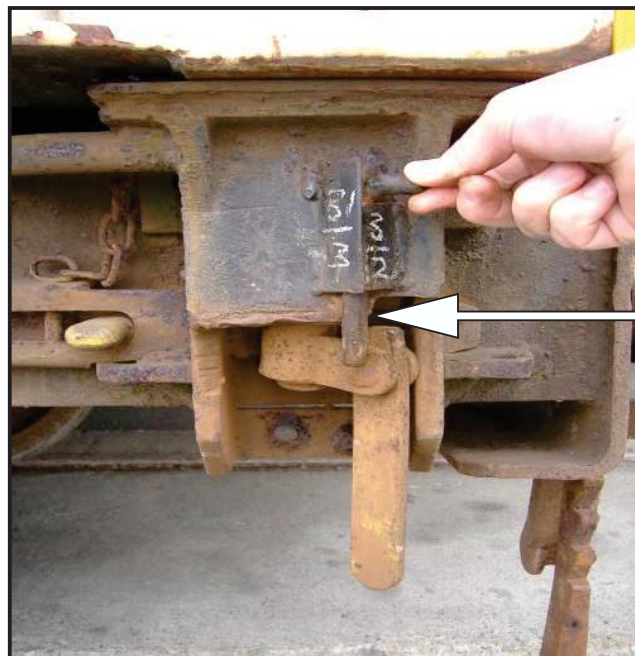

Security pin engaged

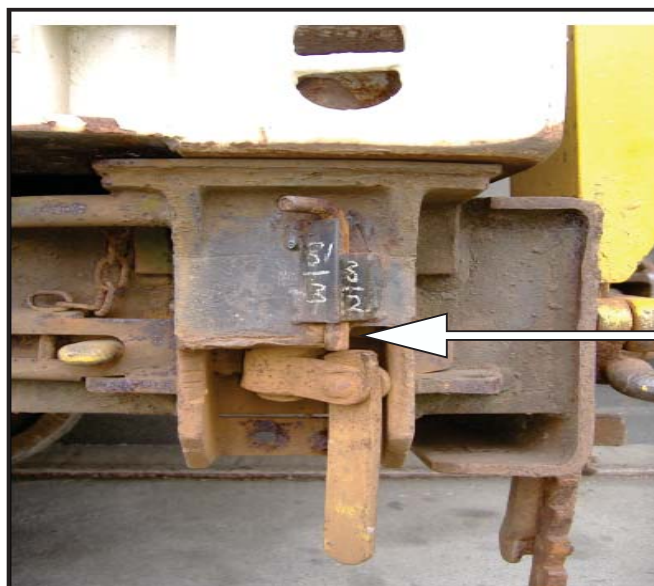

Security pin not engaged

DIAGRAM 12.20 SECURING A CONTAINER

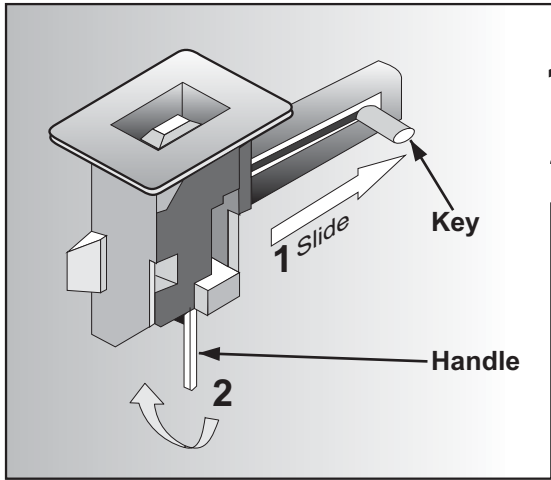

- 1** Slide twistlock key away from twistlock body. This unlocks the unit.
- 2** Grasp the Handle. Lift it up 90 degrees, so that it is parallel to the ground

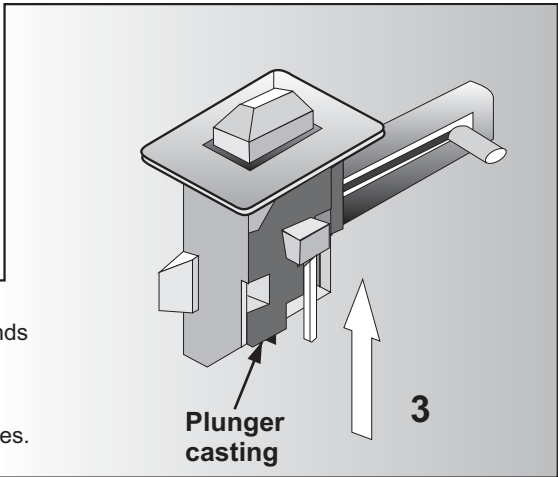

- 3** Pull the handle straight up to lift the twistlock plunger assembly up. You may have to use both hands if the twistlock is stiff.
If so, pull the handle up with one hand and push on the bottom of the plunger casting with the other. You will have to lift the plunger up about 75 millimetres.

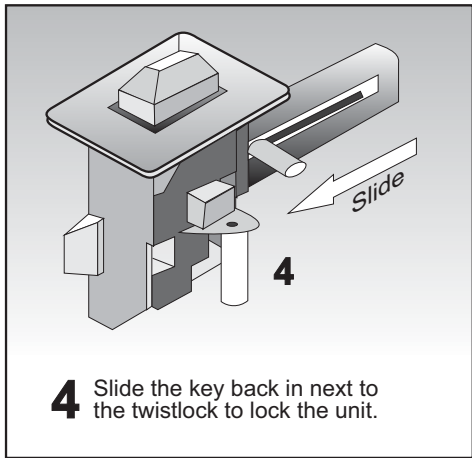

- 4** Slide the key back in next to the twistlock to lock the unit.

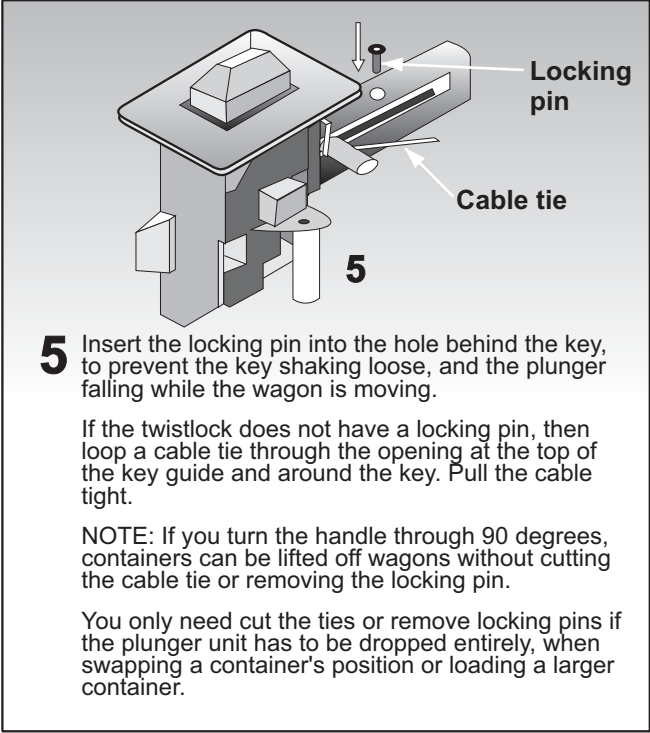

- 5** Insert the locking pin into the hole behind the key, to prevent the key shaking loose, and the plunger falling while the wagon is moving.

If the twistlock does not have a locking pin, then loop a cable tie through the opening at the top of the key guide and around the key. Pull the cable tight.

NOTE: If you turn the handle through 90 degrees, containers can be lifted off wagons without cutting the cable tie or removing the locking pin.

You only need cut the ties or remove locking pins if the plunger unit has to be dropped entirely, when swapping a container's position or loading a larger container.

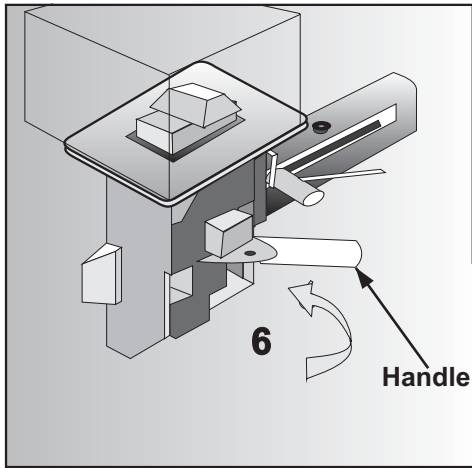

- 6** After loading the container, rotate the handle 90 degrees to the right. This locks the plunger into the container's corner casting.
The handle should now be at 90 degrees to its position when you started. Let go of the handle and allow it to drop to the vertical position.

DIAGRAM 12.21 AUTOMATIC TWISTLOCKS

The automatic twistlocks on **USQ** wagons are **FULLY AUTOMATIC** and **DON'T** require manual operation for either loading or unloading.

The emergency release pins are provided to enable the twistlock head to turn freely with no spring action operating.

Use the emergency release pins **ONLY IF**:

- Lifting Equipment capacity is insufficient to lift container plus 2 tonnes for the twistlocks, or;
- One or more twistlocks fail to operate when the container is lifted normally, or;
- Container is being removed from a derailed wagon and sudden movements are undesirable.

TO OPERATE EMERGENCY RELEASE PINS

1. Pull the emergency release pin out and rotate the head a little towards the unlocked position to keep the pin out against its spring.
2. Repeat for each twistlock.
3. Lift the container from the wagon.
4. Rotate the head until the pin springs back in and check that it can no longer freely rotate. Repeat for each twistlock.



REMEMBER

- RELEASE PINS ARE ONLY FOR USE IN EMERGENCIES
- THE PIN MUST BE PUSHED BACK IN AFTER USE
- THE TWISTLOCK HEAD MUST BE CHECKED TO ENSURE IT CAN NO LONGER TURN FREELY

DIAGRAM 12.22 NEW MODEL AUTOMATIC TWISTLOCKS

Normal Position:

- ➔ Yellow indicator should be retracted
- ➔ Indicator will be momentarily visible as the twistlock is locked or opened.
- ➔ Twistlock head will be at a 45 degree angle



Defective Twistlock:

- ➔ Yellow indicator will not be retracted
- ➔ Twistlock head will be at a 90 degree angle (as shown below)



DIAGRAM 12.23 MANUAL / REMOVABLE TWISTLOCKS

Manual movable twistlocks to allow for different combinations of containers which must be manually configured for the load to be carried.

Moving Twistlocks

- ➔ Turn whole twistlock body and lift it to remove
- ➔ Drop twistlock in the required wagon mount bracket and turn the whole twistlock body to lock it in place
- ➔ Storage slots are provided for unused twistlocks
- ➔ Damaged twistlocks can be easily replaced

Locked / Released Position

- ➔ Rotate the twist handle to the left to lock and
- ➔ right to release

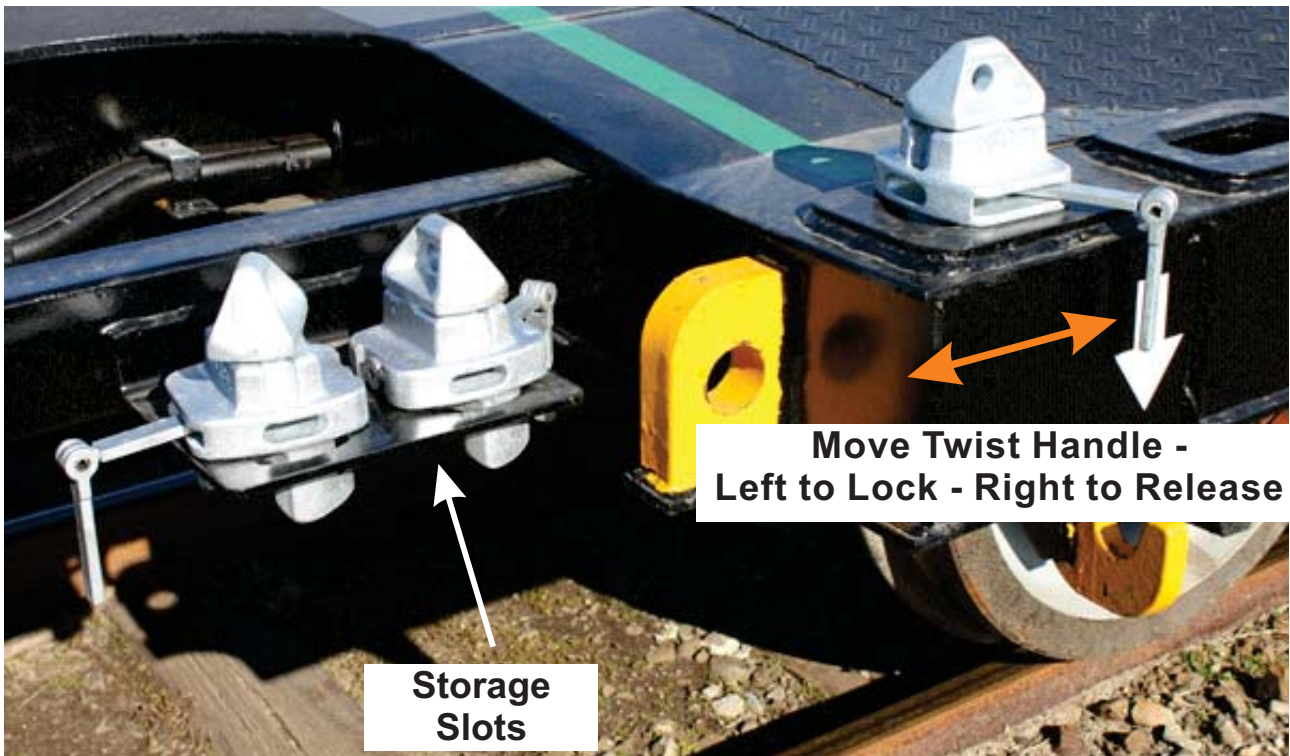
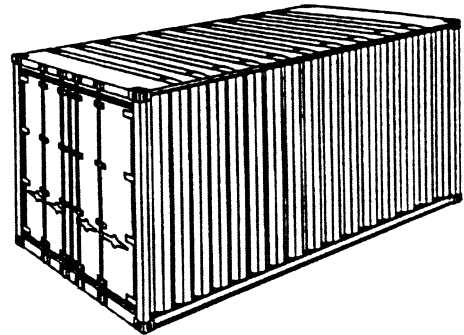

DIAGRAM 12.24 CONTAINER TYPES
Sheet 1 of 3

GENERAL BOX CONTAINER

Six metres (twenty feet) and twelve metres (forty feet) long containers used for ordinary cargo.



HIGH CUBE CONTAINER

Overheight containers used for light, bulky or high loads. Most are twelve metres (forty feet) long. Height is 2.8 or 2.9 m.

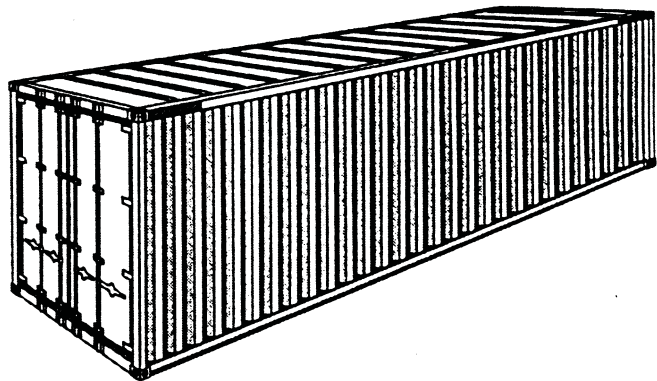

HARD TOP CONTAINER

Six metres (twenty feet) long containers with removable solid steel roofs. Used for heavy lifts, excessively high cargoes, and for loading from above, e.g., by crane. Some units have a removable doorheader to make loading and unloading easier.

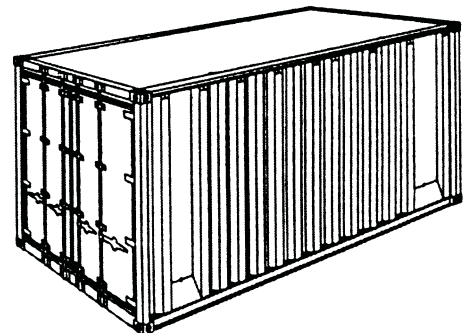

OPEN TOP CONTAINER

Six metres (twenty feet) and twelve metres (forty feet) long containers with removable tarpaulin cover. Used for excessively high cargoes and for loading from above, e.g., by crane.

Some units have a removable doorheader to make loading and unloading easier.

Frequently referred to as TILT containers by British shippers.

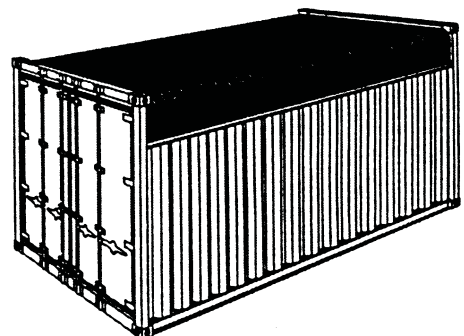

Diagrams continued on next page...

DIAGRAM 12.24 CONTAINER TYPES
Sheet 2 of 3

FLAT RACK CONTAINER

Six metres (twenty feet) and twelve metres (forty feet) long containers used for heavy lift and out of gauge cargoes.

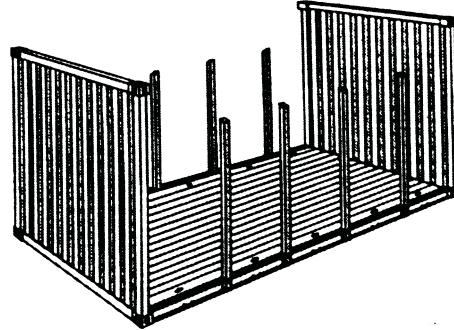

PLATFORM CONTAINER

Six metres (twenty feet) and twelve metres (forty feet) long containers used for heavy lift and out of gauge cargoes.

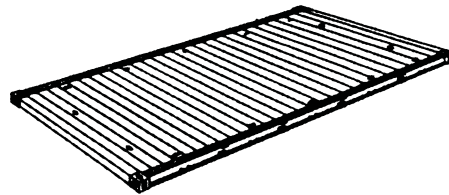

VENTILATED CONTAINER

Six metres (twenty feet) long containers used for cargoes requiring ventilation.

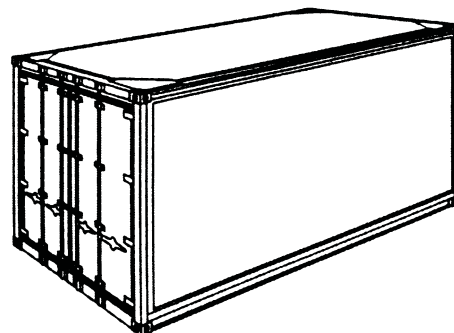

Diagrams continued on next page...

DIAGRAM 12.24 CONTAINER TYPES
Sheet 3 of 3

INTEGRAL REEFER CONTAINER

Six metres (twenty feet) and twelve metres (forty feet) long insulated containers used for cargo requiring transport at a constant temperature. The refrigeration unit is built in to the container.

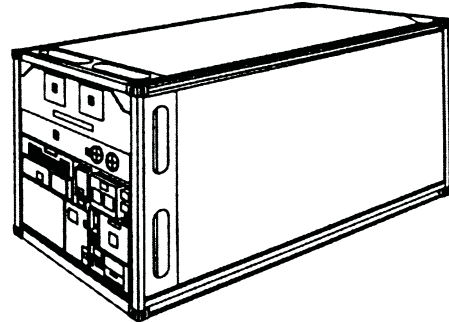

BULK CONTAINER

Six metres (twenty feet) long containers used for loose bulk cargoes such as grain.

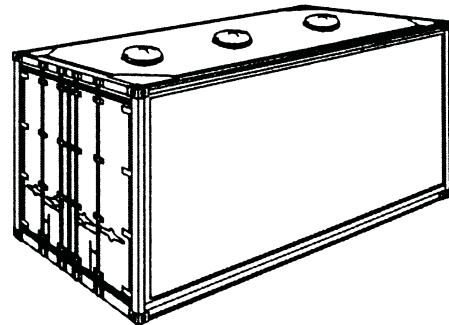

TANK CONTAINER

Six metres (twenty feet) long containers used to transport liquid chemicals and food products.

